



KERNEL-210
KERNEL-220



**High Performance
MEMS Inertial
Measurement Units**

The **Inertial Labs MEMS KERNEL-210 and KERNEL-220 Inertial Measurements** are the third generation of the Inertial Labs Miniature MEMS sensor-based family. The KERNEL-210 and KERNEL-220 are revolutionary, compact, self-contained, strapdown, Tactical-grade Inertial Measurement Units that measure linear accelerations and angular rates with precision due to their aligned and calibrated three-axis MEMS accelerometers and three-axis MEMS gyroscopes. Angular rates and accelerations are determined with low noise and very good repeatability for both motionless and dynamic applications.



The **Inertial Labs KERNEL-210 and KERNEL-220** models are the breakthrough, fully integrated inertial sensors that combines the latest MEMS sensor technologies. **KERNEL-220** model utilizes two types of accelerometers: with $\pm 40g$ and $\pm 90g$ measurement ranges.

Fully calibrated, temperature compensated, mathematically aligned to an orthogonal coordinate system, the IMU contains less than 1 deg/hr Bias in-run stability gyroscopes and 0.005 mg Bias in-run stability accelerometers with very low noise and high reliability.

Continuous Built-in Test (BIT), configurable communications protocols and flexible input power requirements make the **Inertial Labs KERNEL** easy to use in a wide range of higher order integrated system applications.



The **Inertial Labs KERNEL** models were designed for applications, like:

- ❖ Autonomous vehicles
- ❖ Antenna and Line of Sight Stabilization Systems
- ❖ Passengers trains acceleration / deceleration and jerking systems
- ❖ Motion Reference Units (MRU) and Motion Control Sensors (MCS)
- ❖ Gimbals, EOC/IR, platforms orientation and stabilization
- ❖ GPS-Aided Inertial Navigation Systems (INS)
- ❖ Attitude and Heading Reference Systems (AHRS)
- ❖ Guidance and Navigation
- ❖ UAV & AUV/ROV navigation and control



Parameter	KERNEL-210 Tactical	KERNEL-220 Tactical	
GYROSCOPES			
Measurement range	± 2000 deg/sec	± 2000 deg/sec	
Gyroscopes Bias in-run stability	1 deg/hr	1 deg/hr	
Gyroscopes Bias residual error (over temp. range)	<30 deg/hr	<30 deg/hr	
Gyroscopes Noise - Angular Random Walk	0.2 deg/vhr	0.2 deg/vhr	
ACCELEROMETERS			
Measurement range	$\pm 8g$ (15g/40g)	$\pm 8g$ (15g/40g) and	$\pm 90g$
Accelerometers Bias in-run stability	0.005 mg	0.005 mg	1 mg
Accelerometers Bias instability over temp. range	0.5 mg	0.5 mg	200 mg
Accelerometers Noise (Velocity Random Walk)	0.015 m/sec/vhr	0.015m/sec/vhr	15 m/sec/vhr
PITCH & ROLL	0.05 deg	0.05 deg	

KERNEL-210 and KERNEL-220 Tactical

	Parameter	Units	KERNEL-210 Tactical	KERNEL-220 Tactical
GENERAL	Output signals		Pitch, Roll, Accelerations, Angular Rates, Temp., Synch	Pitch, Roll, Accelerations, Angular Rates, Temp., Synch
	Color of Enclosure		Gold	Gold
	Update rate (IMU data)	Hz	2000	2000
	Update rate (Pitch & Roll data)	Hz	2000	2000
	Start-up time	sec	<0.02	<0.02
	Full Accuracy Data (Warm-up Time)	sec	<0.05	<0.05
	Latency	milli sec	<1	<1
PERFORMANCE	Pitch & Roll	Units	KERNEL-210 Tactical	KERNEL-220 Tactical
	Data rate	Hz	2000	2000
	Range: Pitch	deg	±90	±90
	Range: Roll	deg	±180	±180
	Angular Resolution	deg	0.01	0.01
	Static Accuracy, RMS	deg, 1σ	0.05	0.05
	Dynamic Accuracy, RMS	deg, 1σ	0.08	0.08
	Gyroscopes	Units	KERNEL-210 Tactical	KERNEL-220 Tactical
	Measurement range	deg/sec	±2000	±2000
	Bandwidth (-3dB)	Hz, 1σ	260	260
	Data update rate	Hz	2000	2000
	Bias in-run stability (Allan Variance, RMS)	deg/hr, 1σ	1	1
	Bias repeatability (turn-on to turn-on, RMS)	deg/hr, 1σ	15	15
	Bias residual error (over temp. range, RMS)	deg/hr, 1σ	30	30
	SF accuracy (over temperature range)	ppm, 1σ	750	750
	Noise. Angular Random Walk (ARW)	deg/Vhr, 1σ	0.2	0.2
	Non-linearity	ppm, 1σ	100	100
	Axis misalignment	mrad, 1σ	0.15	0.15
	Accelerometers	Units	KERNEL-210 Tactical	KERNEL-220 Tactical
	Measurement range	g	±8 / ±15 / ±40	±8 / ±15 / ±40 and ±90
	Bandwidth (-3dB)	Hz, 1σ	260	260
	Data update rate	Hz, 1σ	2000	2000
	Bias in-run stability (RMS, Allan Variance)	mg, 1σ	0.005 / 0.01 / 0.02	0.005 / 0.01 / 0.02
	Bias residual error (in temp. range, RMS)	mg, 1σ	0.5 / 0.7 / 1.2	0.5 / 0.7 / 1.2
	Bias one-year repeatability	mg, 1σ	1.0 / 1.3 / 1.5	1.0 / 1.3 / 1.5
	SF accuracy (over temperature range)	ppm, 1σ	150 / 300 / 500	150 / 300 / 500
	SF one-year repeatability	ppm, 1σ	500 / 1300 / 1500	500 / 1300 / 1500
	Noise. Velocity Random Walk (VRW)	m/sec/Vhr, 1σ	0.015 / 0.035 / 0.045	0.015 / 0.035 / 0.045
Non-linearity	ppm, 1σ	150 / 150 / 150	150 / 150 / 150	
Axis misalignment	mrad, 1σ	0.15 / 0.15 / 0.15	0.15 / 0.15 / 0.15	
Environment	Units	KERNEL-210 Tactical	KERNEL-220 Tactical	
Mechanical shock	g, msec	400 g, 0.1 ms	400 g, 0.1 ms	
Vibration	g RMS, Hz	8, 10 – 2000	8, 10 – 2000	
Operating temperature	deg C	-40 to +85	-40 to +85	
Storage temperature	deg C	-50 to +90	-50 to +90	
Low pressure	Pa, min	1750, 30	1750, 30	
Humidity	%	up to 95	up to 95	
MTBF (G _M @ +65degC, operational)	hours	100,000	100,000	
Life time (operational)	years	10	10	
Life time (storage)	years	17	17	
Electrical	Units	KERNEL-210 Tactical	KERNEL-220 Tactical	
Supply voltage	V DC	5.4 - 36	5.4 - 36	
Power consumption	Watts	0.5	0.55	
Output Interface	-	RS422 + discrete IOs	RS422 + discrete IOs	
Output data format	-	Binary, ASCII, KERNEL	Binary, ASCII, KERNEL	
Physical	Units	KERNEL-210 Tactical	KERNEL-220 Tactical	
Size	mm	28.38 x 19.5 x 10.5	28.38 x 19.5 x 10.5	
Weight	grams	15	17	

KERNEL-210 and KERNEL-220 Industrial

Parameter		Units	KERNEL-210 Industrial	KERNEL-220 Industrial
GENERAL	Output signals		Pitch, Roll, Accelerations, Angular Rates, Temp., Synch	Pitch, Roll, Accelerations, Angular Rates, Temp., Synch
	Color of Enclosure		Gold	Gold
	Update rate (IMU data)	Hz	2000	2000
	Update rate (Pitch & Roll data)	Hz	2000	2000
	Start-up time	sec	<0.02	<0.02
	Full Accuracy Data (Warm-up Time)	sec	<0.05	<0.05
Latency	milli sec	<1	<1	
Pitch & Roll		Units	KERNEL-210 Industrial	KERNEL-220 Industrial
Data rate	Hz	2000	2000	
Range: Pitch	deg	±90	±90	
Range: Roll	deg	±180	±180	
Angular Resolution	deg	0.01	0.01	
Static Accuracy, RMS	deg, 1σ	0.05	0.05	
Dynamic Accuracy, RMS	deg, 1σ	0.08	0.08	
Gyroscopes		Units	KERNEL-210 Industrial	KERNEL-220 Industrial
Measurement range	deg/sec	±2000	±2000	
Bandwidth (-3dB)	Hz, 1σ	260	260	
Data update rate	Hz	2000	2000	
Bias in-run stability (Allan Variance, RMS)	deg/hr, 1σ	3	3	
Bias repeatability (turn-on to turn-on, RMS)	deg/hr, 1σ	30	30	
Bias residual error (over temp. range, RMS)	deg/hr, 1σ	50	50	
SF accuracy (over temperature range)	ppm, 1σ	4000	4000	
Noise. Angular Random Walk (ARW)	deg/vhr, 1σ	0.3	0.3	
Non-linearity	ppm, 1σ	200	200	
Axis misalignment	mrad, 1σ	0.3	0.3	
Accelerometers		Units	KERNEL-210 Industrial	KERNEL-220 Industrial
Measurement range	g	±8 / ±15 / ±40	±8 / ±15 / ±40 and ±90	
Bandwidth (-3dB)	Hz, 1σ	260	260	
Data update rate	Hz, 1σ	2000	2000	
Bias in-run stability (RMS, Allan Variance)	mg, 1σ	0.01 / 0.03 / 0.05	0.01 / 0.03 / 0.05	
Bias residual error (in temp. range, RMS)	mg, 1σ	0.7 / 1.1 / 1.5	0.7 / 1.1 / 1.5	
Bias one-year repeatability	mg, 1σ	1.5 / 2.0 / 2.5	1.5 / 2.0 / 2.5	
SF accuracy (over temperature range)	ppm, 1σ	500 / 700 / 850	500 / 700 / 850	
SF one-year repeatability	ppm, 1σ	800 / 1400 / 1700	800 / 1400 / 1700	
Noise. Velocity Random Walk (VRW)	m/sec/vhr, 1σ	0.02 / 0.045 / 0.06	0.02 / 0.045 / 0.06	
Non-linearity	ppm, 1σ	340 / 800 / 1000	340 / 800 / 1000	
Axis misalignment	mrad, 1σ	0.3 / 0.3 / 0.3	0.3 / 0.3 / 0.3	
Environment		Units	KERNEL-210 Industrial	KERNEL-220 Industrial
Mechanical shock	g, msec	400 g, 0.1 ms	400 g, 0.1 ms	
Vibration	g RMS, Hz	8, 10 – 2000	8, 10 – 2000	
Operating temperature	deg C	-40 to +85	-40 to +85	
Storage temperature	deg C	-50 to +90	-50 to +90	
Low pressure	Pa, min	1750, 30	1750, 30	
Humidity	%	up to 95	up to 95	
MTBF (G _M @+65degC, operational)	hours	100,000	100,000	
Life time (operational)	years	10	10	
Life time (storage)	years	17	17	
Electrical		Units	KERNEL-210 Industrial	KERNEL-220 Industrial
Supply voltage	V DC	5.4 - 36	5.4 - 36	
Power consumption	Watts	0.5	0.55	
Output Interface	-	RS422 + discrete IOs	RS422 + discrete IOs	
Output data format	-	Binary, ASCII, KERNEL	Binary, ASCII, KERNEL	
Physical		Units	KERNEL-210 Industrial	KERNEL-220 Industrial
Size	mm	28.38 x 19.5 x 10.5	28.38 x 19.5 x 10.5	
Weight	grams	15	17	

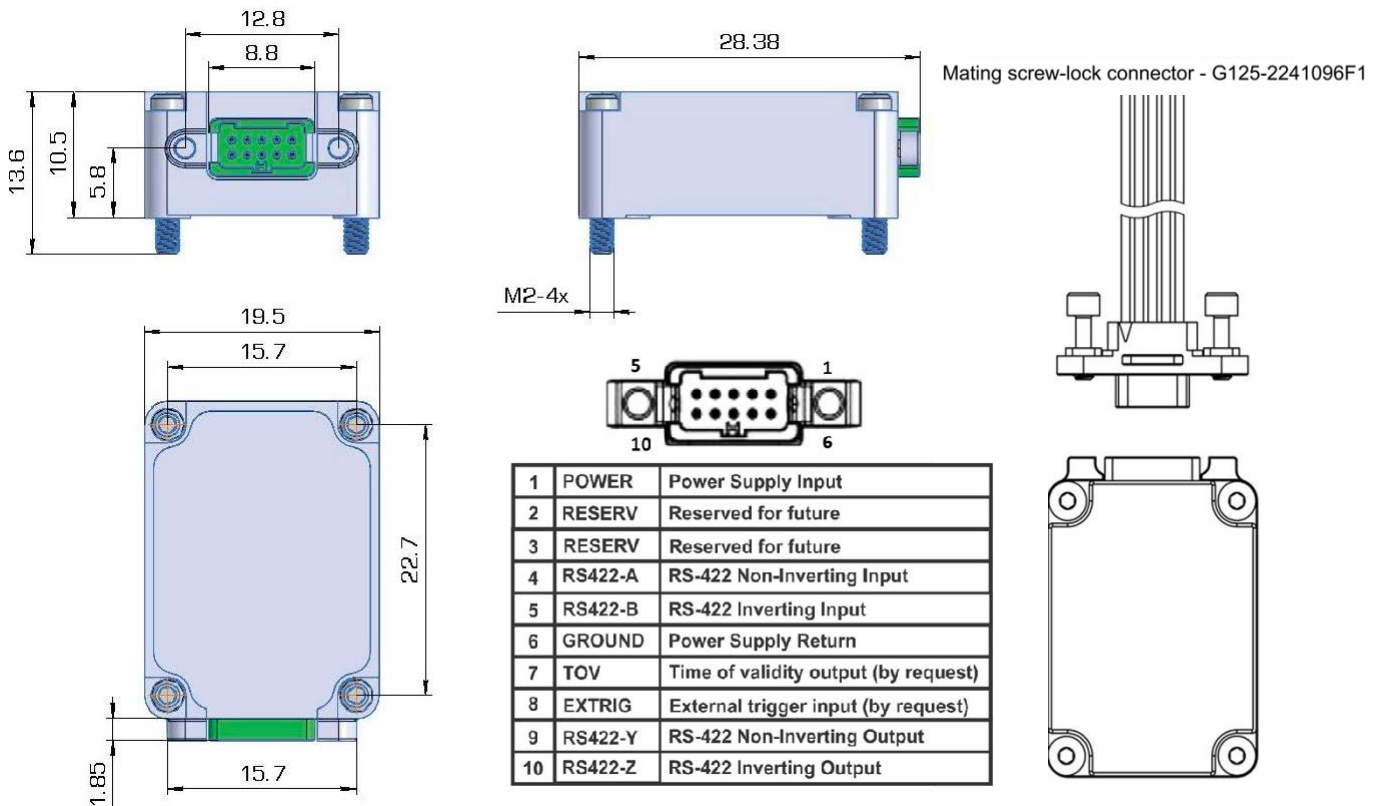
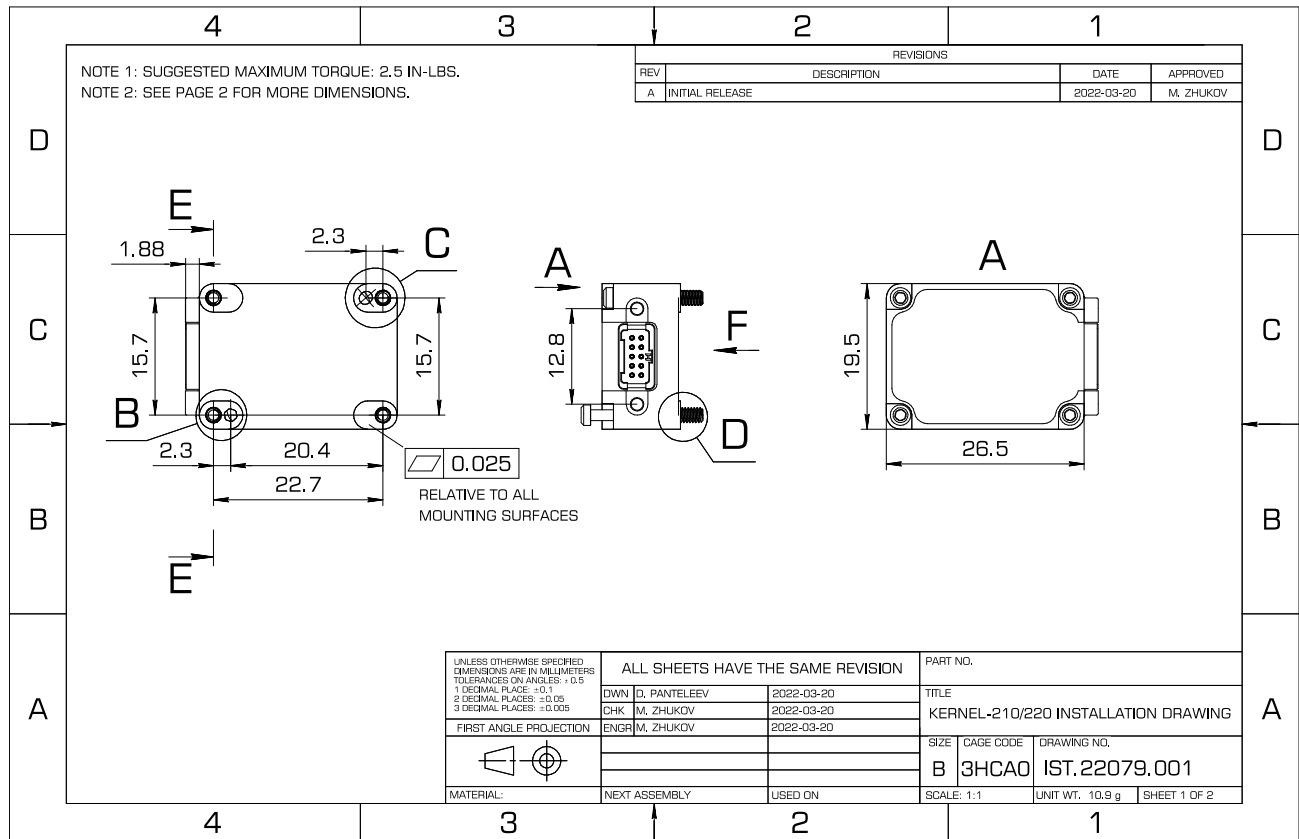
KERNEL-210 and KERNEL-220 Mechanical & Electrical Interfaces Description

KERNEL-210 Product Code structure

Model	Gyroscope	Accel	Calibration	Connector	Color	Version	Interface
KERNEL-210	G2000	A8	TGA	C12	A	V1	2
		A15				V2	
		A40					

KERNEL-220 Product Code structure

Model	Gyroscope	Accel	Calibration	Connector	Color	Version	Interface
KERNEL-220	G2000	A8A90	TGA	C12	A	V1	2
		A15A90				V2	
		A40A90					

Example:

KERNEL-210-G2000-A15-TGA-C12-A-V1.2

KERNEL-220-G2000-A40A90-TGA-C12-A-V1.2

Product code details:

- G2000: Gyroscopes measurement range = ± 2000 deg/sec
- A8: Accelerometers measurement range = ± 8 g
- A15: Accelerometers measurement range = ± 15 g
- A40: Accelerometers measurement range = ± 40 g
- A8A90: Accelerometers measurement range = ± 8 g and ± 90 g
- A15A90: Accelerometers measurement range = ± 15 g and ± 90 g
- A40A90: Accelerometers measurement range = ± 40 g and ± 90 g
- TGA: Gyroscopes and Accelerometers are calibrated over temperature range
- C12: Aluminum case (Captive screws; reference mechanical drawing)
- A: Color of enclosure: Aurum (Gold)
- V1: Tactical
- V2: Industrial
- .2: RS-422 interface